

J5F-WIFI-B / J5F-IP-W



- Commercial Touchscreen Wi-Fi Thermostat
- Standard (Gas/Electric), 1H/1C
- Heat Pump, 1H/1C with Aux Heat
- Auto-Changeover Heating/Cooling
- Up to 3-Speed Fan
- Humidity Sensing & Dehumidification Control
- NetX Internal Expansion Port
- 7 Day Programmable + 80 Calendar Events
- Onboard Data Logging

GENERAL DESCRIPTION:

Complete Stand-Alone Solution

The J5F-WIFI-B (black case) and J5F-WIFI-W (white case) are Wi-Fi touchscreen thermostats, designed for new or replacement commercial and residential applications. Use the J5F-WIFI for either conventional and heat pump applications (Gas/Elect 1H/1C, HP 1H/1C) focused on FCU applications with up to 3 speed fans. The JF-WIFI also has a revolutionary NetX Expansion Port for the NetX CO₂ sensor, NLC Lighting Control, or other future accessories. The powerful processor allows near effortless setup of your daily schedules (4 events per day) and up to 80 Additional Events (40 Special and 40 Calendar Events). The unique scheduling structure also supports the powerful features of adjustable temporary override times and temperature ranges, occupied and unoccupied events, touchscreen lockout, and many more features. In addition to the powerful NetX ecosystem, the J5F-WIFI also includes full both Modbus TCP/IP and BACnet/IP over Ethernet, directly on the thermostat.

The J5F-WIFI is designed to operate with our CloudConnect™ Online Management software or, for maximum security, behind your firewall using DirectConnect™ to the embedded web server. With all functions stored in the thermostat, the J5F-WIFI will continue to operate even during network outages, allowing you to maintain your energy savings. For ultimate control over energy usage, the J5F-WIFI offers a digital lockout that can permit limited temperature overrides based on your requirements. The on-board data collection allows for historical review, sub-metering, and run-time reporting.

STANDARD FEATURES:

CloudConnect™ & CloudManager™ Available

Energy Savings

- Efficient Equipment Restart™ randomizes equipment starts to minimize multiple units turning on simultaneously when there are multiple NetX thermostats at the location
- Random Restart on power up staggers restart of HVAC system after a power outage to minimize peak in-rush current
- Adaptive Recovery for Schedules allows system to achieve desired setpoint at the beginning of the schedule

Monitoring

- NetX Expansion Port for CO₂, NLC Lighting, and other future accessories
- On-board Data Logging with Sub-Metering Support

Connectivity

- CloudConnect™ Internet-Based Cloud Service
- PCConnect™ Software Local Network & Port Forwarded Access
- DirectConnect™ Integrated Web Server
- Integrated NetX™ API, Supports 3rd Party Apps
- BACnet/IP and Modbus TCP/IP over Wi-Fi (use either or both)

Facility Management

- 4 independent schedules per day
- 80 Additional Event Schedules (40 Special and 40 Calendar Events)
- Commercial Lockout with Programmable Temporary Override Time and Temp Adjustment
- Min/Max Heating and Cooling Restrictions
- Email & Text Message Alerting for 4 Locations
- Alerts include High/Low Temps for Indoor, Outdoor, Inefficient Equipment Operation, Change Filter Notifications, and more

General

- Sleek Black Touchscreen Display with White Icons, Black or White Case
- Modes: Heat, Cool, Automatic Changeover
- Integrated Humidity Sensing and Dehumidification Control
- Fan Selector for Independent Fan Control, up to 3 Fan Speeds
- Programmable Recirculation Fan
- Integrated Weather with Current Conditions and 7-Day Forecasts
- Embedded Web Server with responsive design allowing access from any device with a browser



SPECIFICATIONS:

Rated Voltage: 20V to 30VAC, 24VAC nominal

Rated A.C. / D.C. Current: 0.05 to 0.75 AC / 0.0 to 0.75 DC Amp continuous, per output, surges to 3 Amps maximum

Temperature Control Range: Heating: 38°F to 88°F (4°C to 31°C) in 1° steps **Cooling:** 60°F to 108°F (16°C to 42°C) in 1° steps

Thermostat Sensing Range: 32°F to 118°F (0°C to 48°C) **Control Accuracy:** ±1°F @ 68°F (±0.5°C @ 20°C)

Minimum Deadband: 2°F (1°C)

Dimensions: 5.1"H x 3.25"W x 1.08"D (130mm x 82.5mm x 27.4mm)

Mounting: Single Gang Vertical Mount, Standard 3 9/32" Screw Hole Spacing

Equipment Terminations: G1 - Fan 1, G2 - Fan 2, G3/AUX - Fan 3 or Aux Heat, Y-Compressor, W - Heat, O/B - Rev. Valve in Cooling, or Heating

Power Terminations: R - 24V Switching Voltage (from HVAC equipment), 24V - Separate Power (24VAC/DC) requires jumper removal, C - Power Return (from HVAC equipment)

Wireless Radio: 2.4GHz 802.11b/g/n, Security: Open, WEP, WPA-PSK, WPA2-PSK

Internal Expansion Port: SIM port for NetX CO₂ Sensor, NLC Lighting Control, NetX future accessories

WIRING DIAGRAMS:

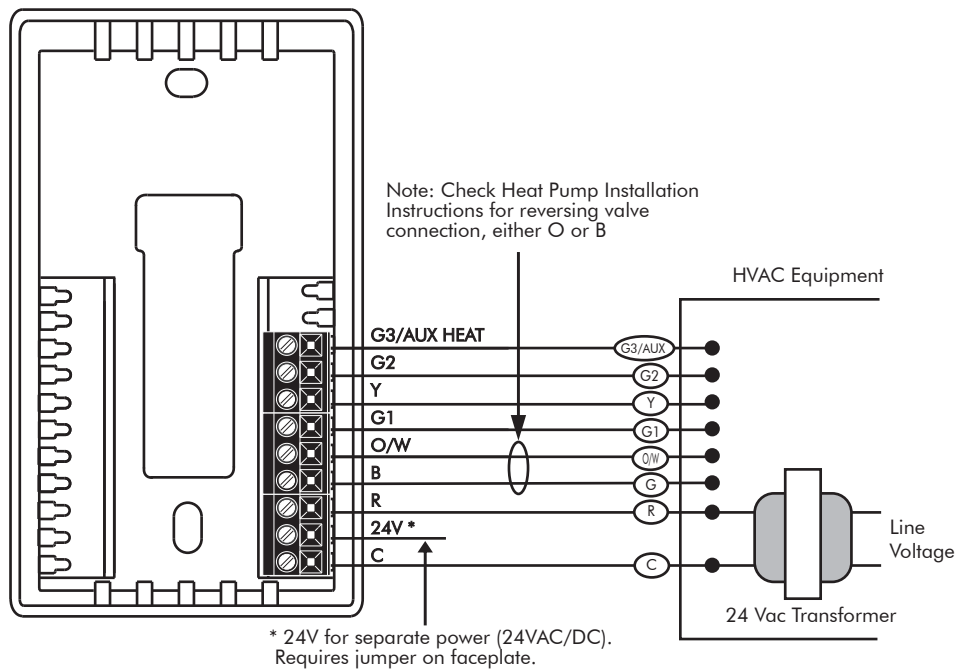

TERMINAL FUNCTIONS

G3/AUX Fan 3, Aux Heat

G2 Fan 2

Y1 Compressor

G Fan 1

O/W O - Reversing Valve, W - Heat

B B - Reversing Valve

R 24VAC Power

24V For Separate RC/RH, Remove Jumper on PCB

C 24V Return